

## AEGIS WTG™ Wind Turbine Bearing Protection Ring™

- Protects wind turbine generators from catastrophic bearing failure
- Safely channels harmful shaft voltages to ground
- Easily retrofit during bearing change or maintenance
- Proven design - Engineered for any size wind turbine generator

### PROBLEM:

#### Shaft Currents Damage Wind Turbine Generators

Induced shaft voltages, often measured over 1200 volts peak, are present on the shaft of wind turbine generators. These voltages cause high frequency bearing currents over 60 amps, which result in pitting, fluting and catastrophic bearing failure in as little as six months. Turbine failures cost tens of thousands of dollars in system down time, repairs, and lost revenue.

### SOLUTION:

#### AEGIS WTG™ - Bearing Protection Ring™

AEGIS WTG™ Bearing Protection Ring™ protects wind generator bearings from catastrophic failure. Tested up tower, the specially engineered Bearing Protection Ring™ is capable of channeling even the highest voltages and currents safely away from the bearings to ground.

Generators and gear boxes are protected ensuring greater system reliability and up time.

#### Fits all wind generators including:

ABB	Teco
Elin	Toshiba
Hitachi	VEM
Leroy Somer	WEG
Loher	Weier
Marathon	Winergy

#### Available in split ring design for up-tower installation

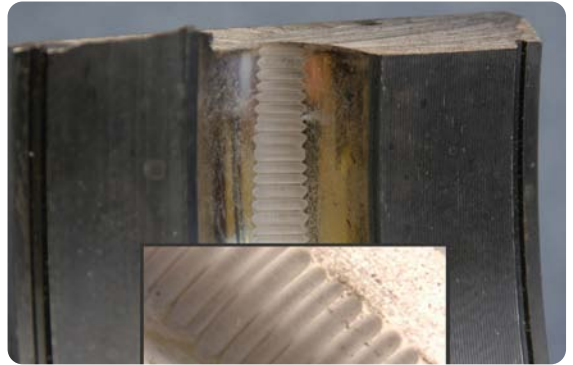

Visit our website for a distributor in your area.  
[www.morgancarbon.com](http://www.morgancarbon.com)

## AEGIS WTG™ Bearing Protection Ring™

### AEGIS WTG 120™

- High frequency shaft currents up to 13.5 MHz
- Compatible with monitoring equipment
- Long term reliable performance

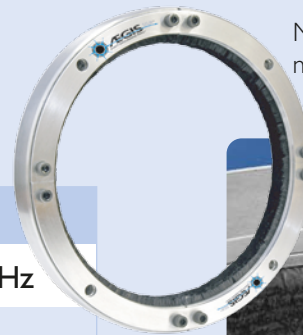

Metric screws for standard mounting included.

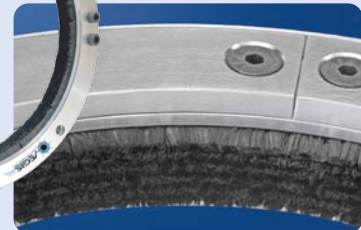

Six rows of conductive microfiber ensure high current flow.

### Split Ring Dimensions

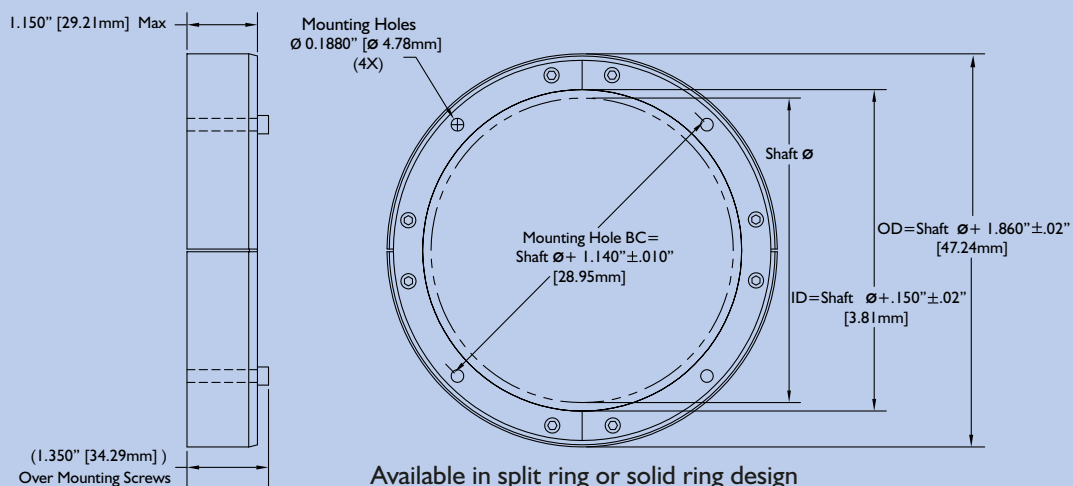

Note:

1. Shaft must be clean & free of any coatings, paint, or other nonconductive material.
2. WTG split ring is assembled around the shaft and is locked in place with the locking collar and mounting brackets.
3. WTG should be installed by an authorized WTG installer.

Learn more about protecting wind turbines from catastrophic bearing failure at: [www.morgancarbon.com](http://www.morgancarbon.com)

**Fits all wind turbine models including:**

GE Energy	Fuhrlander	Vestas	Gamesa	Clipper	Neg-Micon
Siemens	Acciona	Suzlon	Enron	Mitsubishi	Zond